

Swing H1-01

Catalogue No.: H1-01

3-15

1



Dimensions	1,90 m x 1,97 m x 2,36 m
Safety zone	2,12 m x 7,55 m
Height of free fall	1,30 m
Number of users	1
Age	3-15 years
Material	<ul style="list-style-type: none"> - steel or glued laminated timber beams - top beam made from steel - galvanised carbon or stainless steel fasteners - stainless steel chains - polypropylene ropes with steel core - soft rubber seats with metal core - galvanised carbon steel anchors (for wooden structures)

Safety zone

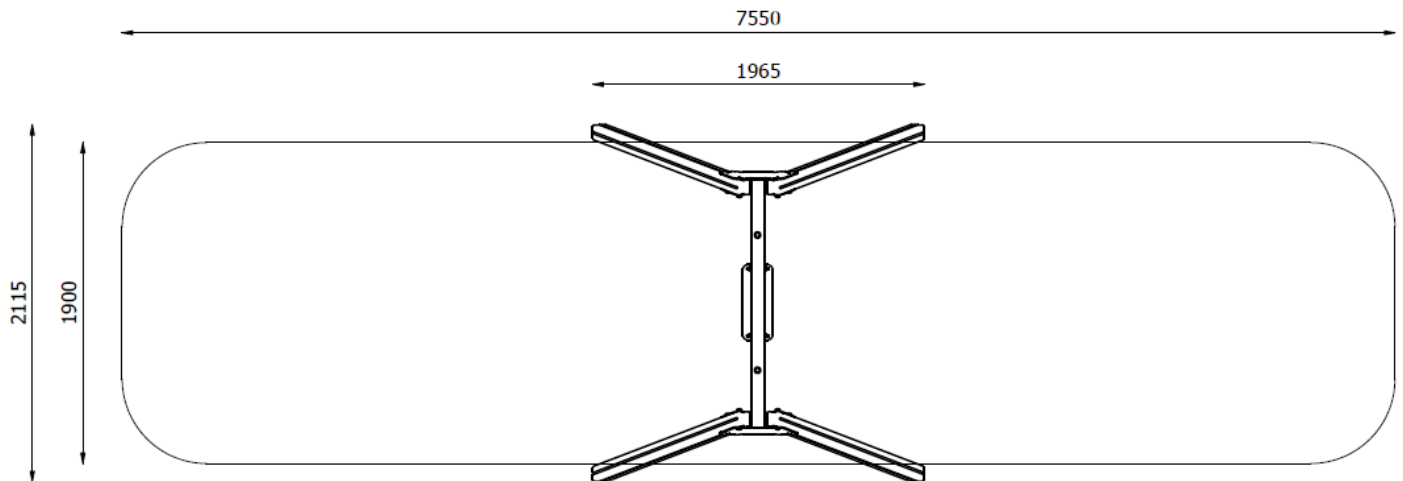

Description

The construction made of bonded laminated wood with dimensions of 90x90 mm, impregnated with a vacuum-pressure method or of carbon steel with corrosion protection by galvanizing and powder coating or of stainless steel. The upper beam profile 90x90 mm of carbon steel with corrosion protection by galvanizing and double powder coating. The chain of stainless steel, calibrated, rendering finger seizing impossible. The swing slings of galvanized carbon steel or stainless steel. The flat and bucket seat made from durable rubber with a metal insert.

Way of seating

The device structure mounted on carbon steel, galvanized anchors. The anchors sunk in concrete directly in the ground.

The manufacturer indicates that the real appearance of the above presented device may differ from visualization. All the construction or colouring changes are related to continuous process of device quality and aesthetics improvement.